

FEATURES

- **Compatible with NEMA 34 Motors**
- **Backlash as Low as 7 arc-min**
- **Thirteen Gear Ratios From 3 to 64**
- **Patented Precision Clamping System**
- **Lifetime Lubrication**
- **High Durability**
- **30,000 Hours Design Life**
- **96% Efficient**



DESCRIPTION

The GBPN-090x-FS Series Planetary Gearbox offers you the precision you need at the prices you want! This Planetary Gearbox is designed with the highest torque density possible for motion control, automation, and robotic applications requiring a compact solution. This planetary gearbox series is an ideal match for the NEMA 34 frame size as well as your servo, stepper, brushless, AC or DC motors. Built with the design goal of offering a cost-effective product without sacrificing quality, you will find that this Planetary Gearbox offers you an extraordinary value. You will find online prices on this website along with all the information you need to know to select the perfect Planetary Gearbox for your applications.

SPECIFICATIONS

Model #	Gear Ratio (X:1)	Rated Output Torque (oz-in)	Max Output Torque (oz-in)	Rated Input Speed (RPM)	Max Input Speed (RPM)	Stages	Backlash Maximum (arcmin)	L2 Length (mm)	Weight (lbs)
GBPN-0901-FS-003-xxxxx-yyy	3	12032	19258	4000	7000	1	<7	66	6.4
GBPN-0901-FS-004-xxxxx-yyy	4	16288	26054	4000	7000	1	<7	66	6.4
GBPN-0901-FS-005-xxxxx-yyy	5	15568	24922	4000	7000	1	<7	66	6.4
GBPN-0901-FS-008-xxxxx-yyy	8	7072	11328	4000	7000	1	<7	66	6.4
GBPN-0902-FS-009-xxxxx-yyy	9	18400	29453	4000	7000	2	<9	83	7.3
GBPN-0902-FS-012-xxxxx-yyy	12	16992	27187	4000	7000	2	<9	83	7.3
GBPN-0902-FS-015-xxxxx-yyy	15	15568	24922	4000	7000	2	<9	83	7.3
GBPN-0902-FS-016-xxxxx-yyy	16	16992	27187	4000	7000	2	<9	83	7.3
GBPN-0902-FS-020-xxxxx-yyy	20	16992	27187	4000	7000	2	<9	83	7.3
GBPN-0902-FS-025-xxxxx-yyy	25	15568	24922	4000	7000	2	<9	83	7.3
GBPN-0902-FS-032-xxxxx-yyy	32	16992	27187	4000	7000	2	<9	83	7.3
GBPN-0902-FS-040-xxxxx-yyy	40	15568	24922	4000	7000	2	<9	83	7.3
GBPN-0902-FS-064-xxxxx-yyy	64	7072	11328	4000	7000	2	<9	83	7.3

Part numbers are based on the specifications of the motor being matched to the gearbox.

-xxxxx denotes motor pilot, -yyy denotes input shaft diameter.

Refer to *Matching the Gearbox to Your Motor* on the second page for more information, or contact an Anaheim Automation Applications Engineer for assistance.

L010615

Radial Load:	315 lbs - Force	Axial Load:	675 lbs - Force
Operating Temperature:	-13° C - 194°F	Iso Output:	9409
Efficiency:	94-96%	IP Rating:	IP 54/55
Lubrication:	Synthetic Grease Kluberplex BEM 34-132"	Noise Level:	60 dBA

Matching the Gearbox to Your Motor

There are a few details that you need to consider before purchasing a gearbox. The gearbox must be manufactured to match the motor’s bolt hole circle, pilot diameter, shaft diameter, and shaft length. This is handled by a code in the last two sections of the part number. For instance, in the part number GBPN-0901-FS-003-AA341-500, the “AA341” is for an Anaheim Automation NEMA 23 Motor pilot and the shaft length. The “250” is for the shaft diameter of 0.250”. For non-standard requirements, contact Anaheim Automation, Inc.

Parameter	Range	Typical
Input Shaft Diameter	13mm to 19mm	“500” - 12.7mm shaft diameter
Input Shaft Length	40mm max	“AA341” - 31.75mm
Pilot	50mm to 80mm	“AA341” - 73.02mm
Bolt Hole Circle	70mm to 100mm	“AA341” - 98.42mm

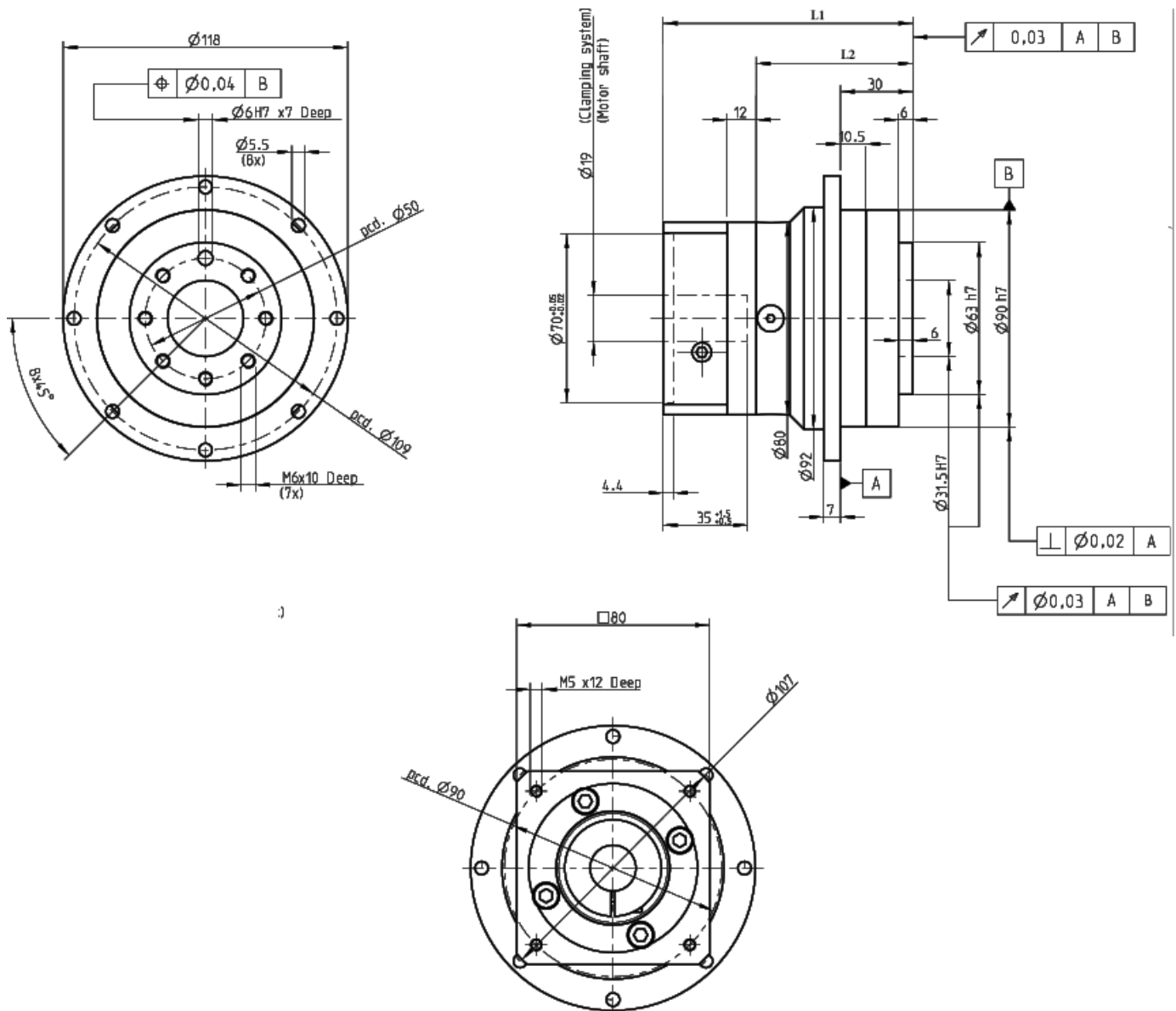

ITEM	DESCRIPTION	MOTOR INTERFACE			
		AA341-500	AA341-625	BLK32-748	EMJ80-748
D1	Input Shaft Diameter	12.7	15.875	19	19
L4	Max Shaft Length	32	32	35	35
D2	Pilot Diameter	73.025	73.025	70	70
L5	Pilot Depth	5.3	5.3	4.4	4.4
D3	Mounting Bolt Hole Circle	98.4	98.4	90	90
D4	Bolt Hole Size	M5x12	M5x12	M5x12	M5x12
L1	Overall Length (1-stage)	101.5	101.5	104.5	104.5
L1	Overall Length (2-stage)	118.5	118.5	121.5	121.5

***1-Stage Models:** Gear Ratios 3-8

***2-Stage Models:** Gear Ratios 9-64